

The Exitronix S900 Series LED Edge-lit Exit features a pivoting design for simple installation in any application, including surface and recessed wall, ceiling and sloped ceilings. Includes surface mounting canopy as well as hardware for recessed mounting applications, making this the most versatile edge-lit sign available. The S900 includes both single- and double-face configurations for easy ordering and stocking.

Model: _____ Date: _____
 Accessories: _____
 Job Name: _____ Type: _____

FEATURES & BENEFITS

- Suitable for installation in existing drywall applications
- Includes both single- and double-face panel configurations
- Includes surface mounting canopy as well as bracket for recessed mounting applications
- UL 924 Listed 90 minute emergency run time, 24 hour recharge time
- Field-selectable directional chevrons
- UL Listed for Damp Locations
- California Energy Commission (CEC) compliant



SPECIFICATIONS

Illumination: Long-life, high-intensity, red or green LEDs
Construction: Extruded aluminum housing with high-grade, acrylic panel
Input: 120/277VAC Dual Primary, 60Hz
Battery: Maintenance-free NiCad battery
Operating Temp: 0°C to 40°C (32°F to 104°F)
Run Time: UL Listed 90 minute emergency run time, 24 hour recharge time
Mounting: Ceiling and end surface mounting or recessed
Finish: Brushed aluminum, black or white
Certifications: UL Listed for Damp Locations, meets or exceeds CEC, NEC and NFPA 101
Warranty: Any component that fails due to a manufacturing defect is guaranteed for five years with a separate three year prorated warranty on the battery. The warranty does not cover physical damage, abuse or instances of uncontrollable natural forces. See the full Exitronix warranty document for detailed information.



CONSTRUCTION

Housing

Available in either a Black, Brushed Aluminum or White finish.

Surface - Engineering grade aluminum extrusion with mounting canopy.

Recessed - Extruded aluminum housing supplied with galvanized steel adjustable bar hanger assembly.

Panels

Constructed of clear acrylic. Stencil letters are 6" high with 3/4" stroke, with minimum of 100' viewing distance rating as required by UL 924 standard. Double-face panels are supplied with a mirror insert. Units are supplied with field-selectable directional chevrons for placement in all applications.

ILLUMINATION

High-output red or green LEDs provide superior brightness. Energy consumption of less than 3W for AC only and less than 5W for battery back-up units. LEDs are a maintenance-free solution.

ELECTRICAL

Input

Dual-voltage input 120 or 277VAC at 60Hz.

Nickel Cadmium Battery - NiCad (With Battery Only)

Exitronix NiCad batteries are maintenance-free.

Emergency (WB Only)

The S900 Series exit will operate for a minimum of 90 minutes during a loss of power with a 24 hour maximum recharge time for the battery.

Solid-State Transfer

The circuit features solid-state switching, eliminating concerns of damaged contact or mechanical failures associated with relays. The switching circuit detects a loss of line voltage and automatically switches to emergency mode.

Low Voltage Disconnect

When the battery's terminal voltage falls below predetermined levels, the low voltage circuit disconnects the emergency lighting load. The disconnect remains in effect until normal power is restored, preventing deep battery discharge and improving the life of the battery. The disconnect will also automatically reconnect the load circuit once the battery voltage returns to a normal value after charging.

Test Button

Test button is easy to locate and allows for manual verification of proper operation of the transfer circuit and emergency lamps.

INSTALLATION

Surface Mounting: completely universal canopy provides for end or ceiling mounting. All hardware is included.

Recessed Mounting: recessed ceiling mount, accessible above the plenum. Electronics and battery contained in housing. Plug-in battery connector supplied for easy installation. All hardware is included.

OPTIONS

Guardian Self-test/Self-diagnostics (Option: G2)

The Guardian circuit continuously monitors the operating condition of the AC power, battery supply voltage and charging circuit.

The purpose of this option is to provide visual signaling in response to a fault at the EXIT sign battery and/or battery charger. If a failure is detected, visual status will occur immediately via the dual color LED. Refer to instruction manual for detailed information.

The Guardian circuit also monitors the transfer circuit as well as performing automatic code compliance testing.

CONFORMANCE TO CODES AND STANDARDS

The S900 Series is UL 924 Listed for Damp Locations. The series meets or exceeds the CEC and NEC requirements as well as NFPA 101.

DIMENSIONS

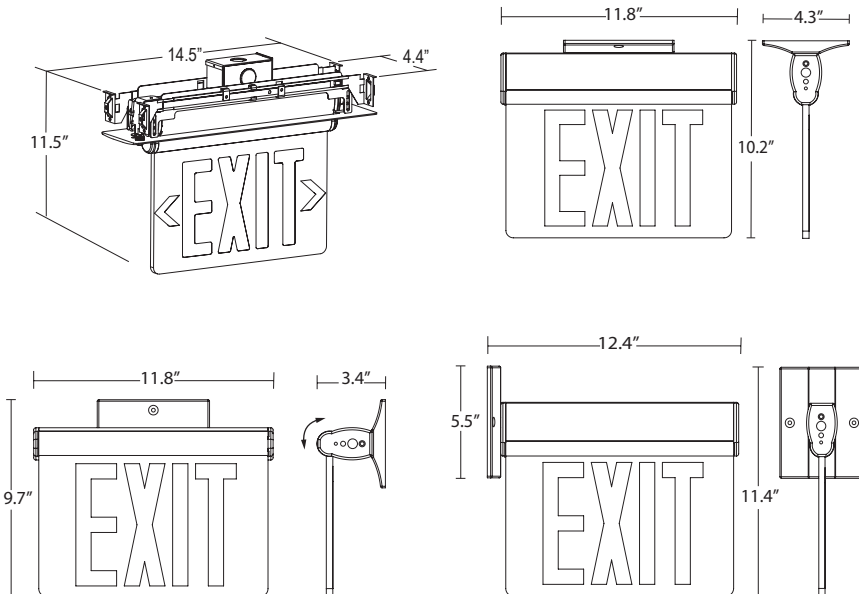

PENDANT ADAPTER

